

3~

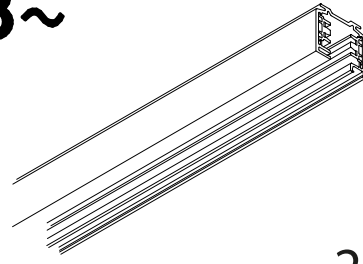

25 ...



③ optional

99-075-. + 99-318-0  
or / oder 99-319-0  
or / oder 88-620-0

③A

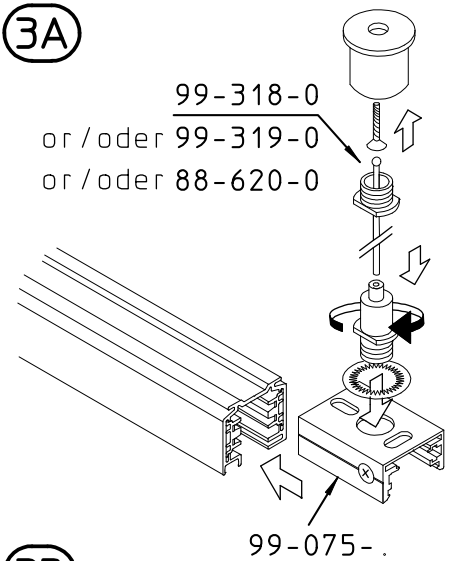

③B

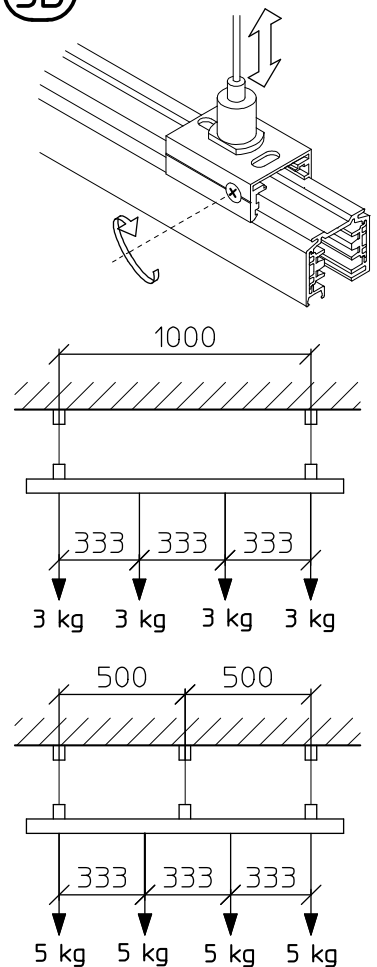

② optional

99-075-. + 99-905-.  
or / oder 99-906-.

②A

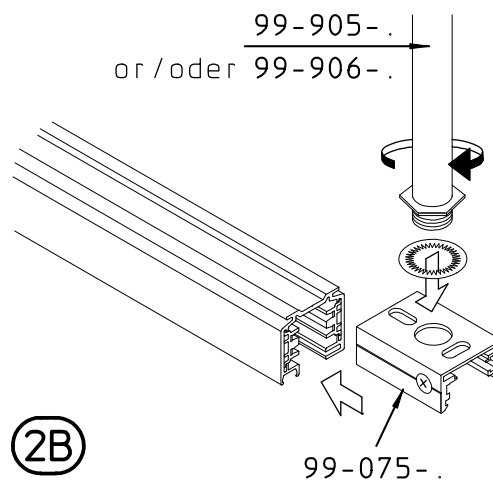

②B

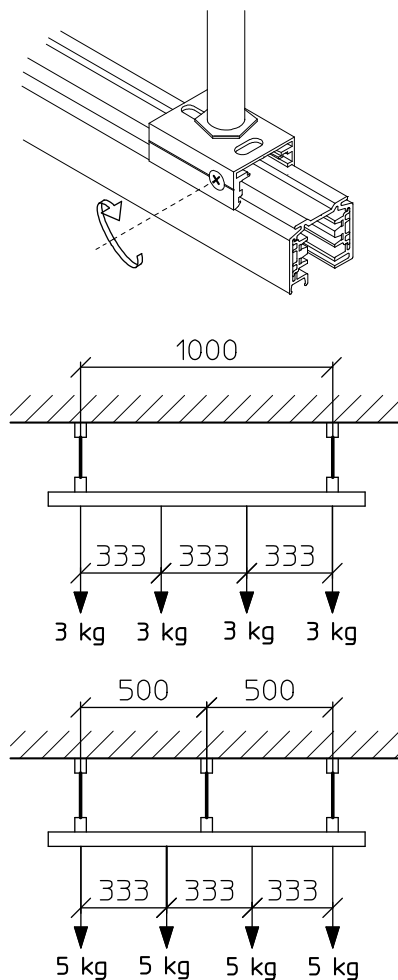

- When cutting do not cut-off labeled side.
- Beim Kürzen nur das nicht etikettierte Ende absägen.

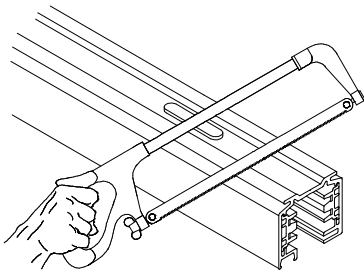

①

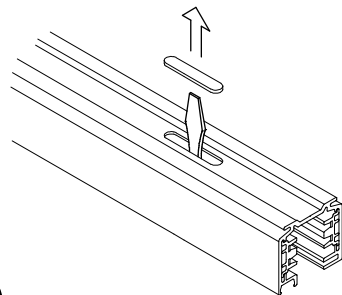

①A

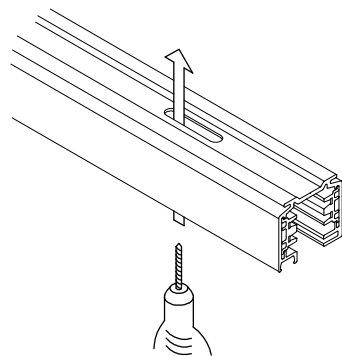

①B

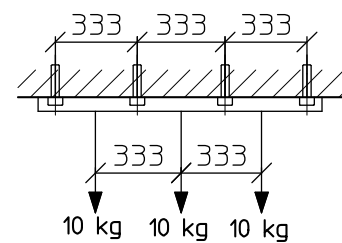
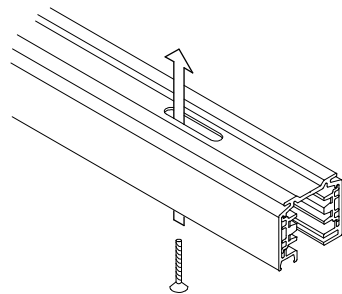

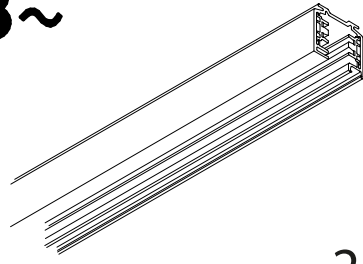

4A

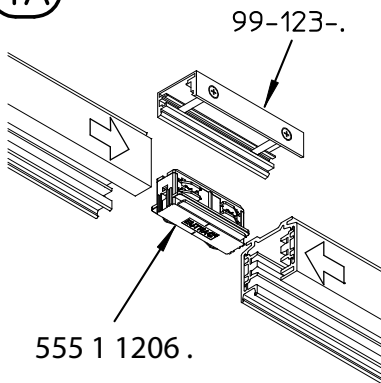

5A

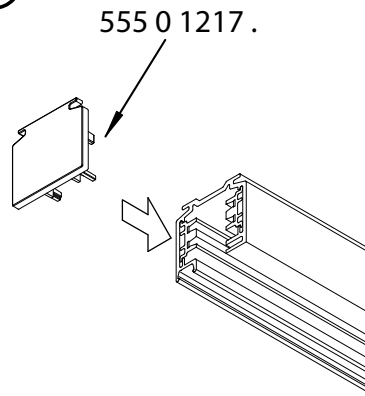

4B

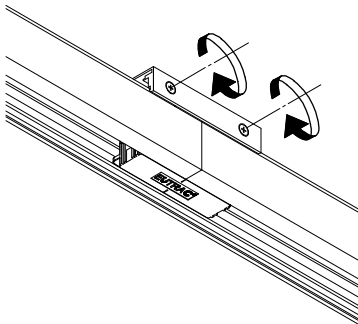

5B

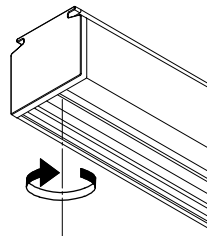

- To be installed by trained personnel only
- It is the responsibility of the installer to ensure the electrical, mechanical and thermal compatibility of the track system and the fittings.
- Materials used for ceiling fixation should conform to relevant building regulations.
- It is essential to cover the ends of the track with end covers or protective caps

- Montage nur durch geschultes Fachpersonal
- Es liegt in dem Verantwortungsbereich des Installateurs, die elektrische, mechanische und thermische Verträglichkeit zwischen dem Stromschienen-System und den daran angebrachten Leuchten sicherzustellen.
- Im Deckenbereich nur baupolizeilich zugelassenes Befestigungsmaterial verwenden.
- Es ist zwingend notwendig, die Stromschienenenden mit Endabdeckung bzw. Schutzkappen zu verschliessen.